

NOTES:

1. EXTERIOR SHALL BE 14 GAUGE #304D STAINLESS STEEL, INTERIOR SHALL BE 14 GAUGE STEEL, PAINTED WHITE. ENCLOSURE SHALL BE ELECTRICALLY WELDED AND REINFORCED WHERE REQUIRED.
2. CONSTRUCTION SHALL BE NEMA 3R AND 12, RAIN TIGHT AND DUST TIGHT.
3. ALL NUTS, BOLTS, SCREWS AND HINGES SHALL BE STAINLESS STEEL.
4. NUTS, BOLTS, AND SCREWS SHALL NOT BE USED ON THE OUTSIDE OF THE SERVICE ENCLOSURE.
5. PHENOLIC NAMEPLATES SHALL BE USED TO IDENTIFY ALL OPERATION CONTROLS.
6. CONTROL WIRING SHALL BE MARKED AT BOTH ENDS BY PERMANENT WIRE MARKERS.
7. A PLASTIC COVERED WIRING DIAGRAM SHALL BE ATTACHED TO THE INSIDE OF THE FRONT DOOR.
8. SERVICE ENCLOSURE SHALL BE FACTORY WIRED AND CONFORM TO REQUIRED NEMA STANDARDS.
9. SERVICE ENCLOSURE SHALL BE U.L. LISTED AS INDUSTRIAL CONTROL PANELS U.L. 508 FILE NO. E62062.
10. WIRING BETWEEN CIRCUIT BREAKER AND CONTACTOR SHALL BE #6 THWN OR THHN MINIMUM.
11. SIZE OF TRANSFORMER FOR SIGNALS SHALL BE 5 KVA. SIZE OF TRANSFORMER FOR 120 V INTERSECTION SHALL BE 2 KVA.
12. WHEN CHANGING VOLTAGE ON A RETROFIT PROJECT WHERE A NEW SERVICE ENCLOSURE WITH A STEP-DOWN TRANSFORMER IS REQUIRED, THE NEW SERVICE ENCLOSURE THE NEW SERVICE ENCLOSURE SHALL BE PLACED BETWEEN THE SERVICE POINT AND THE OLD SERVICE ENCLOSURE LOCATION WITHIN THE CITY R/W. VOLTAGE OUTPUT FROM THE NEW SERVICE ENCLOSURE MAY BE CONNECTED INTO THE EXISTING CONDUIT SYSTEM.
13. THE WIRING SCHEMATIC DIAGRAM AS SHOWN IS FOR A 2-WIRE STREET LIGHTING SYSTEM. IF THE SERVICE ENCLOSURE WILL BE USED FOR A 3-WIRE STREET LIGHTING SYSTEM, THEN THE LIGHTING BREAKERS SHALL CONSIST OF 2-POLE BREAKERS WITH INTERNAL COMMON TRIP, EACH POLE WITH INDIVIDUAL ON-OFF CONTROL AND HANDLE TIE FOR COMMON OPERATION. FOR EACH 2-POLE BREAKER, THE CIRCUIT LOAD SHALL BE EQUALLY DIVIDED ACROSS THE LIGHTING MAIN.
14. SEE STANDARD SPECIFICATIONS FOR ADDITIONAL DETAILS.

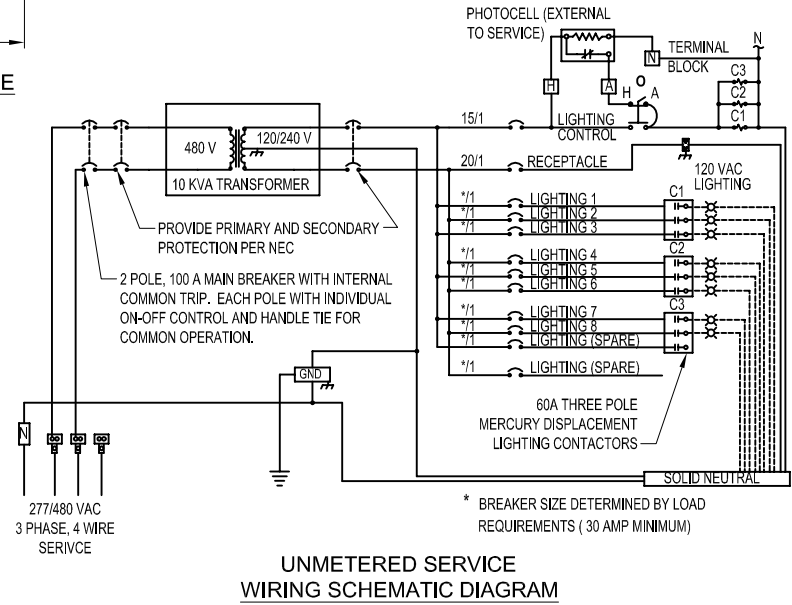

DATE: 01/17/2007		NOT TO SCALE	
REVISION	BY	APPROVED	DATE

CITY OF ELK GROVE - PUBLIC WORKS

**UNMETERED SERVICE ENCLOSURE (CAN)
WITH STEP DOWN TRANSFORMER
(277/480V TO 120/240V)**

APPROVED BY:

CITY ENGINEER

DRAWING NUMBER

SL - 11

