

CLASS A
(CURB, GUTTER & SIDEWALK)

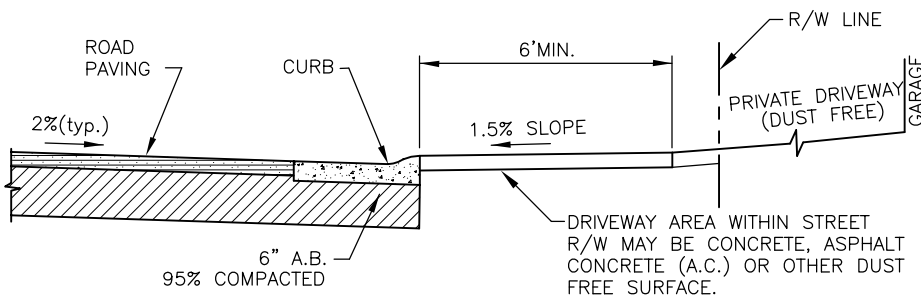

CLASS B
(CURB & GUTTER)

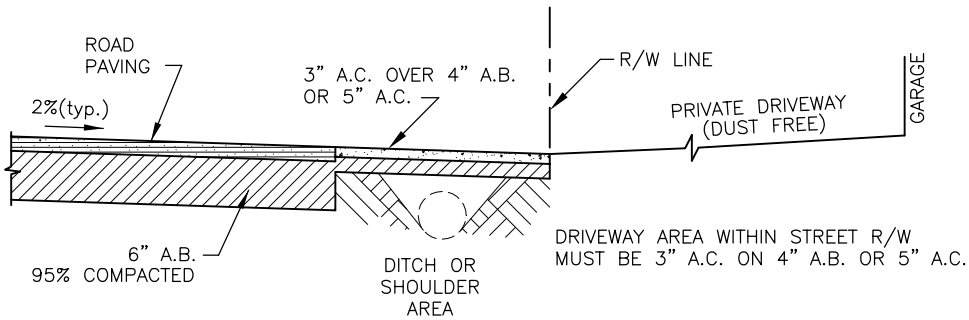

CLASS C
(DITCH OR SHOULDER)

NOTE: SEE CITY OF ELK GROVE IMPROVEMENT STANDARDS SECTION 4-10 FOR DRIVEWAY REQUIREMENTS.

DATE: 02/12/2007		NOT TO SCALE		CITY OF ELK GROVE - PUBLIC WORKS		APPROVED BY:	
REVISION	BY	APPROVED	DATE			CITY ENGINEER	
				TYPICAL STREET SECTIONS AT RESIDENTIAL DRIVEWAYS		DRAWING NUMBER	
						 ST - 19	